

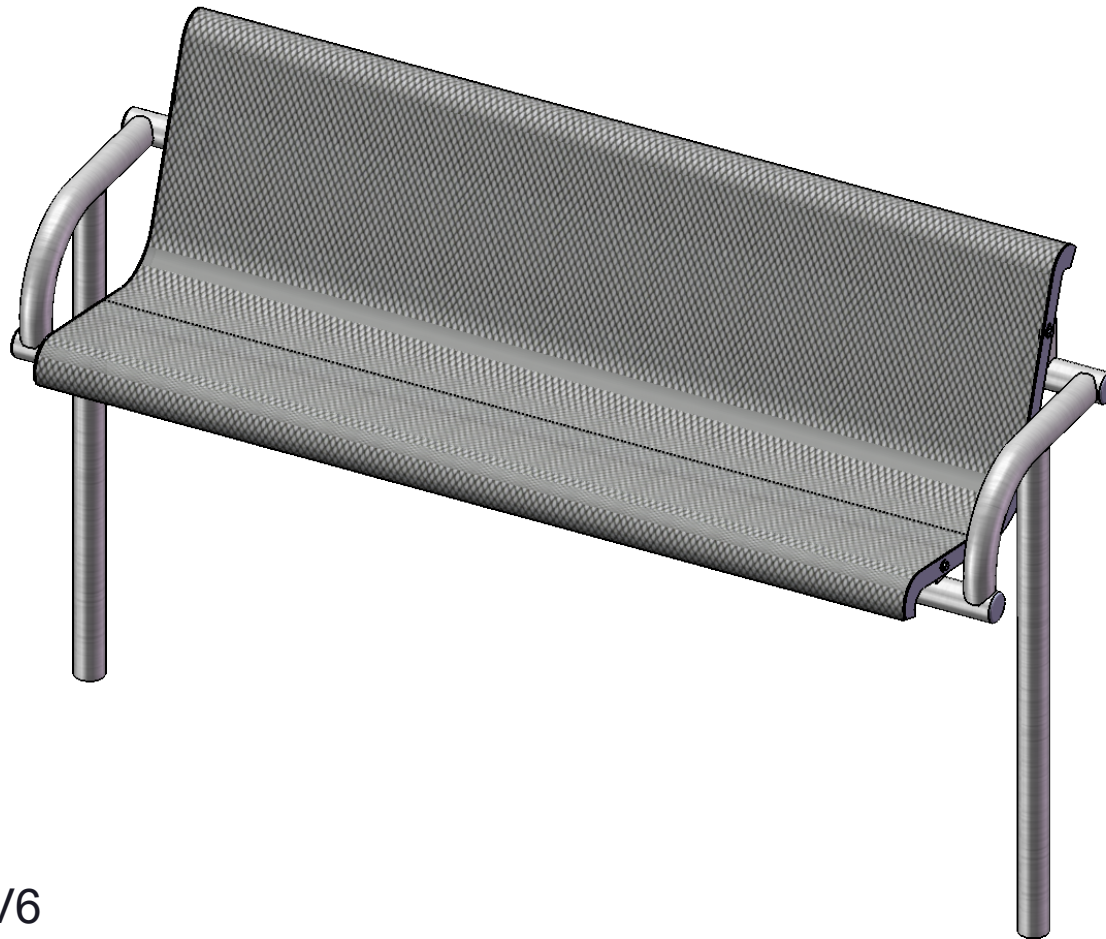

A PLAYCORE Company



Model # 975S-V6



A PLAYCORE Company

## **SAFETY WARNINGS & EQUIPMENT INSPECTION**

- Owners and installers please note these safety warnings and make use of this checklist on a regular basis.
- Follow installation instructions when erecting equipment.
- Ground surfaces around equipment should be restored as needed. Concrete footings should never be exposed. Surface depth should comply with ASTM and CPSC specifications.
- Check for and repair damage caused by wear or vandalism, a major factor in injury causing situations.
- All protruding bolts should be covered or cut off and finished smooth. Sharp edges on pipes should be capped or removed. Check for bent, broken, or severely worn pipe, and replace.
- All equipment should be free of rust and repainted whenever necessary to deter rusting.
- We provide our customers with layout sheets and installation instructions. Please keep on file the specifications sheet that contains the listing of every part used.
- Never add components not intended for use with this product.
- Regular maintenance is necessary in this and all park and recreational equipment to insure the safety of the user.
- Note: Proper maintenance of equipment requires regular tightening of all bolts, nuts, and setscrews.
- Note: Regular checking of all parts, castings, etc. should be made. If a part is broken or worn, it should be replaced immediately.
- Check to be sure all fittings are tight and that bars and pipes do not move.
- Replace all worn S-hooks. S-hooks must be completely closed. Failure to close S-hooks can result in serious injury to the user. NEVER reuse S-hooks.
- Test for free movement of swing hanger and other moving attached parts.
- Check for worn chains and replace them.
- A soft resilient surface should be placed under all swings extending at least twice the height of the top rail both front and back.

# HARDWARE

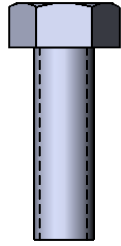

5/16" x 1"  
Machine Bolt

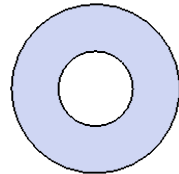

5/16" Washer

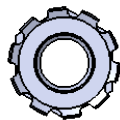

5/16" Kep Nut

## TOOLS REQUIRED

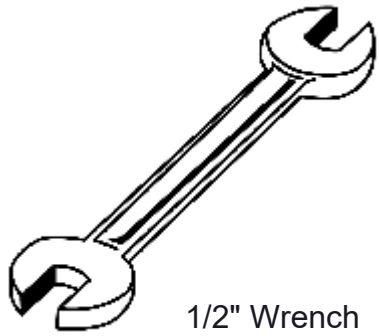

1/2" Wrench

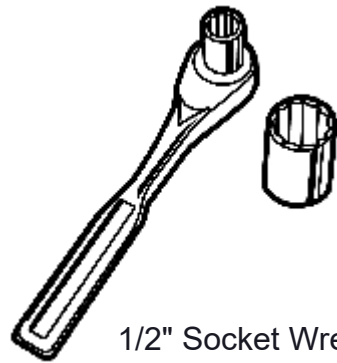

1/2" Socket Wrench

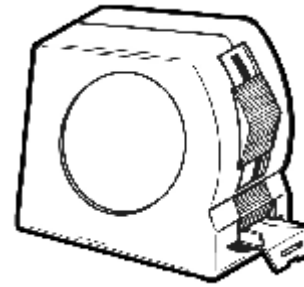

Tape Measure

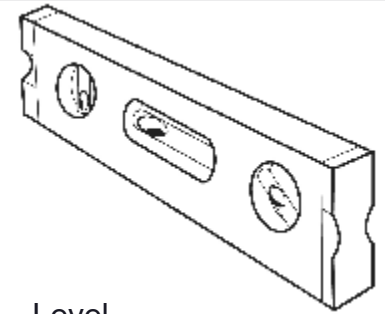

Level

# ULTRA SITE PRODUCT SPECIFICATIONS

## **975S-V6 INGROUND CONTOURED BENCH WITH BACK**

**Seats:** Seats dimensions are 24-3/4" x 15-1/8". #9 steel expanded metal. End plates are made of 10 gauge flat steel plate. Reinforced with 3/16 x 1-1/2" flat strip. Electrically MIG welded.

**Coating:** Oven fused functionalized polyethylene copolymer-based thermoplastic. Fluidized bed coating application with superior mechanical performance, impact resistance and UV-stability.

**Frame:** Legs are 2-3/8" O.D. x 10 gauge pre-galvanized structural steel tubing. Seat support is bent over a mandrel through the bend radius producing a wrinkle free bend. Tube ends are pre-galvanized steel capped. Seat mounting points are 7 gauge x 1-1/2" die stamped steel flat bar. All electrically MIG welded.

**Frame Coating:** Electrostatic powder coated application oven cured.

**Hardware:** All stainless steel hardware fasteners.

**Dimensions:** 6' inground bench with back. Seats are 27" wide x 72" long. Seat height is 18" from the ground to the top of the seat. The overall dimensions are 80-1/2" x 27" x 33-1/2".

# COMPONENTS

Attach the 6' Seat to the 975 Legs using specified hardware.

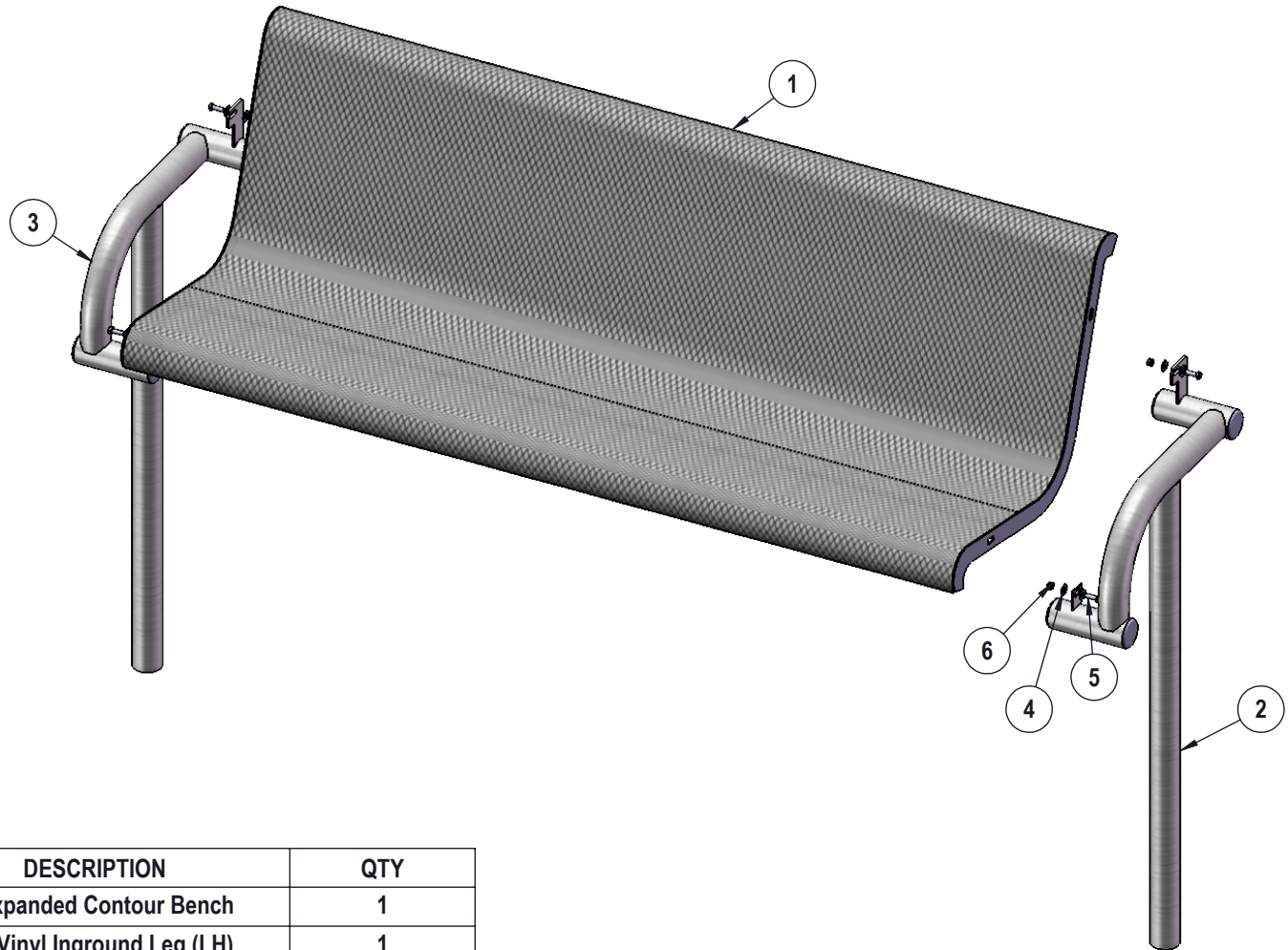

ITEM NO.	PartNo	DESCRIPTION	QTY
1	T-V72CT-S	6' Expanded Contour Bench	1
2	P-V975S-L	975 Vinyl Inground Leg (LH)	1
3	P-V975S-R	975 Vinyl Surface Mount Leg (RH)	1
4	33-02-0007	5/16" SS Washer	8
5	33-05-0029	5/16" x 1" Machine Bolt (SS)	4
6	33-03-0012	5/16" Kep Nut (SS)	4

# FOOTINGS

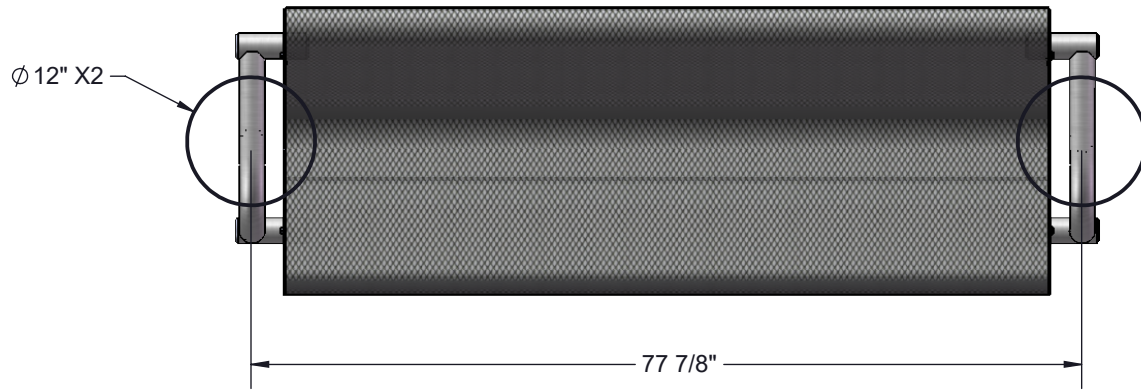

Estimated Required Concrete:  
11 - 50lb Bags of Concrete Mix

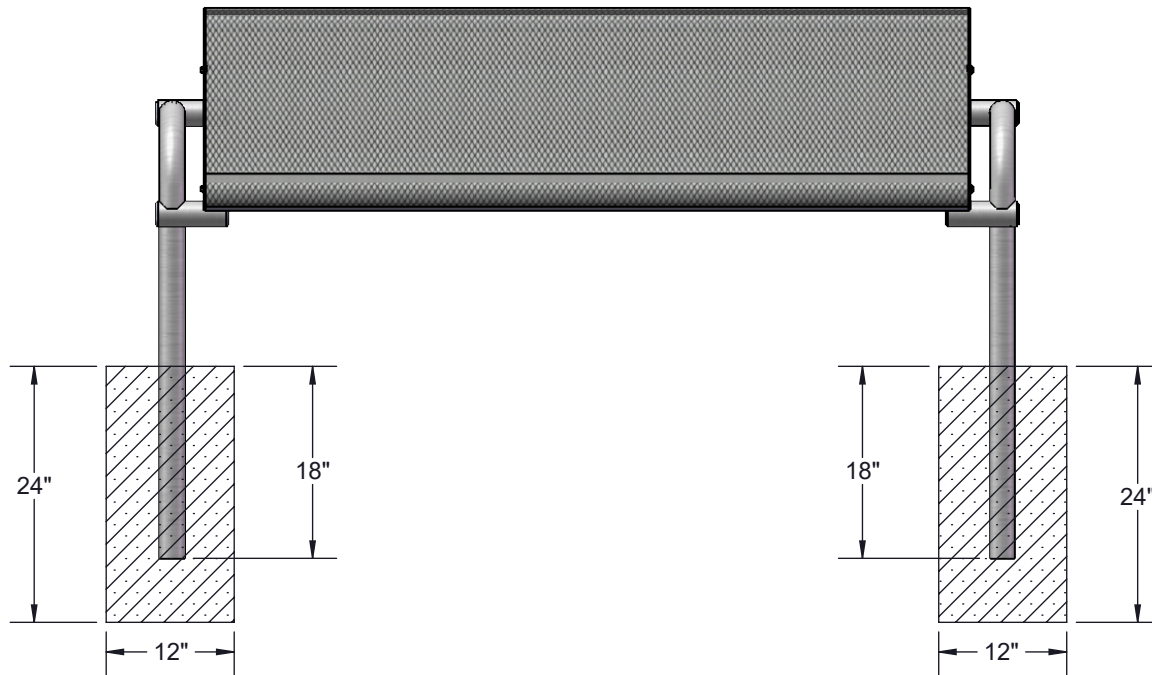

# OVERALL DIMENSIONS

