

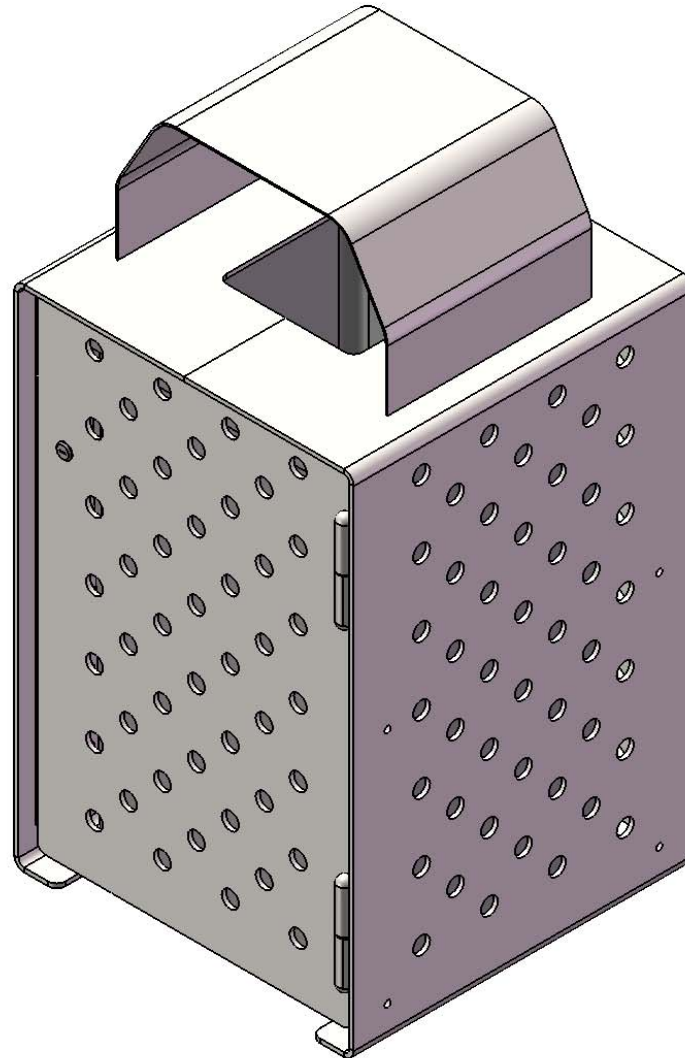

A PLAYCORE Company



Model # 16-P36RB



A PLAYCORE Company

SAFETY WARNINGS & EQUIPMENT INSPECTION

- Owners and installers please note these safety warnings and make use of this checklist on a regular basis.
- Follow installation instructions when erecting equipment.
- Ground surfaces around equipment should be restored as needed. Concrete footings should never be exposed. Surface depth should comply with ASTM and CPSC specifications.
- Check for and repair damage caused by wear or vandalism, a major factor in injury causing situations.
- All protruding bolts should be covered or cut off and finished smooth. Sharp edges on pipes should be capped or removed. Check for bent, broken, or severely worn pipe, and replace.
- All equipment should be free of rust and repainted whenever necessary to deter rusting.
- We provide our customers with layout sheets and installation instructions. Please keep on file the specifications sheet that contains the listing of every part used.
- Never add components not intended for use with this product.
- Regular maintenance is necessary in this and all park and recreational equipment to insure the safety of the user.
- Note: Proper maintenance of equipment requires regular tightening of all bolts, nuts, and setscrews.
- Note: Regular checking of all parts, castings, etc. should be made. If a part is broken or worn, it should be replaced immediately.
- Check to be sure all fittings are tight and that bars and pipes do not move.
- Replace all worn S-hooks. S-hooks must be completely closed. Failure to close S-hooks can result in serious injury to the user. NEVER reuse S-hooks.
- Test for free movement of swing hanger and other moving attached parts.
- Check for worn chains and replace them.
- A soft resilient surface should be placed under all swings extending at least twice the height of the top rail both front and back.

HARDWARE

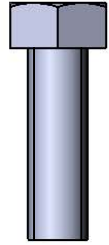

5/16" x 1"
Machine Bolt

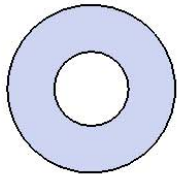

5/16" Flat Washer

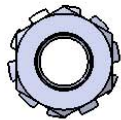

5/16" Kep Nut

TOOLS REQUIRED

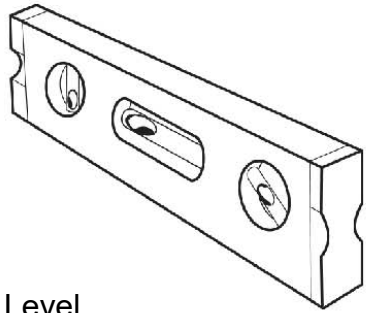

Level

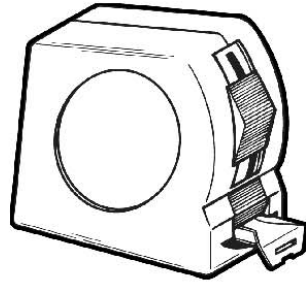

Tape Measure

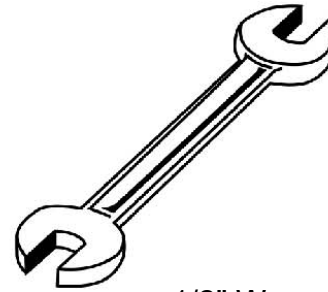

1/2" Wrench

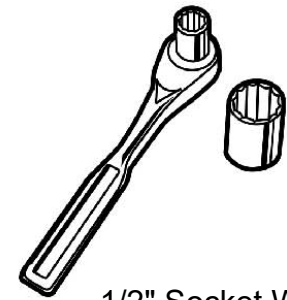

1/2" Socket Wrench

ULTRA SITE PRODUCT SPECIFICATIONS

16-P36RB 36 GALLON TRASH RECEPTACLE

Material: Fabricated with 1/4" steel plates. All electrically MIG welded.

Receptacle Coating: Steel is sandblasted to near white condition. Coated with zinc rich epoxy primer and top coated with electrostatic powder coat, oven cured.

Receptacle Dimensions: 20" x 20" x 30" Tall. Center opening shall be an 8" square.

Rain Bonnet dimensions: 12" x 16" x 6-1/2" high

Hardware: Mounting hardware not included.

36 Gallon Liner: Made of heavy duty plastic.

Overall Dimensions Including Top: 20" x 20 x 36-1/2" high x 36 gallon capacity.

CONNECTING

If connecting Pasadena products together, use the specified hardware to attach them together using the mounting holes on either end.

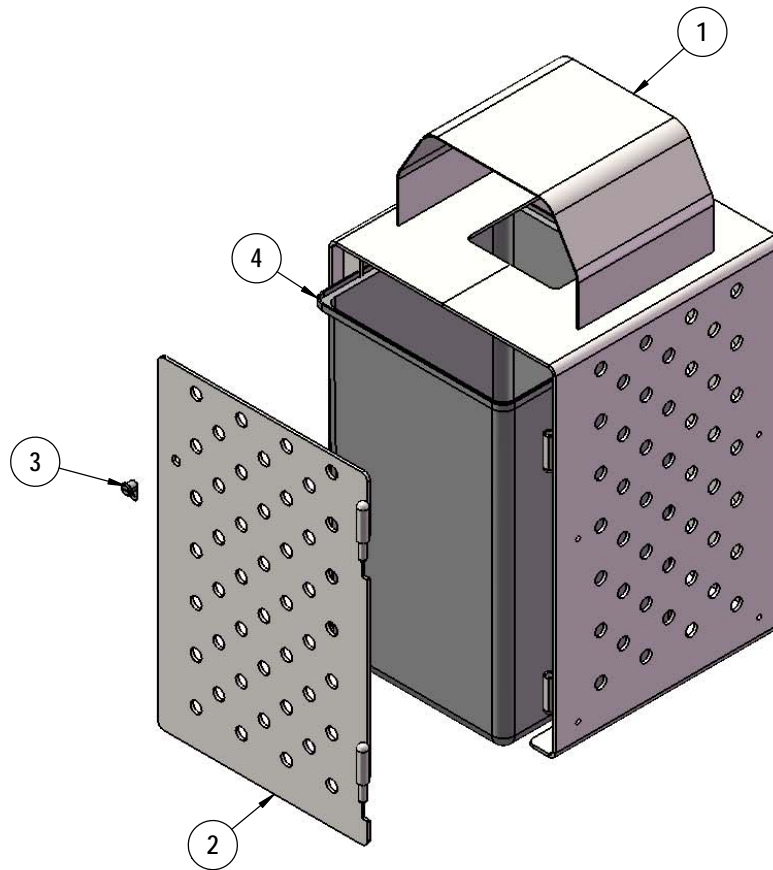

Recommended Surface Mount Hardware:
3/8" x 3-1/2" Concrete Expansion Anchor Bolts
(Not Included)

ITEM NO.	PartNo	DESCRIPTION	Qty.
1	01-05-0272	16 pasadena receptacle base with rain bonnet	1
2	01-05-0275	16 pasadena receptacle door	1
3	01-08-0106	Cabinet Lock w/ Keys (REF# VLT-080813-LM1)	1
4	01-05-0276	36gal plastic liner, 17" x 17" x 27-1/2" tall	1

OVERALL DIMENSIONS

