

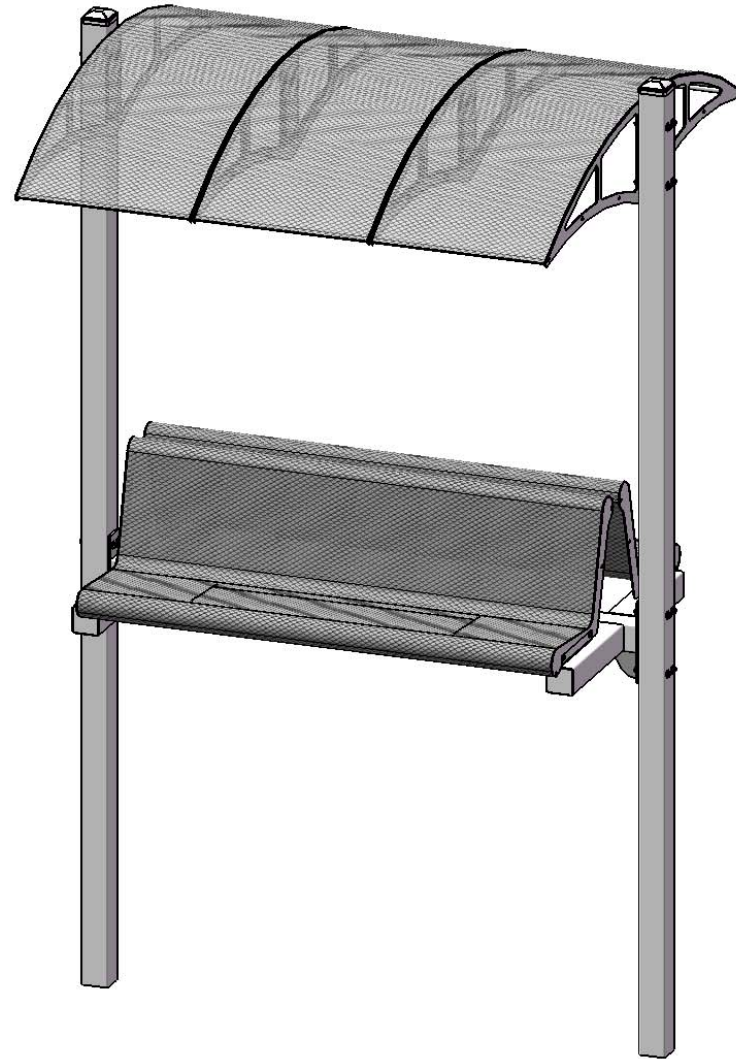

A PLAYCORE Company



Model # 322-V6



A PLAYCORE Company

SAFETY WARNINGS & EQUIPMENT INSPECTION

- Owners and installers please note these safety warnings and make use of this checklist on a regular basis.
- Follow installation instructions when erecting equipment.
- Ground surfaces around equipment should be restored as needed. Concrete footings should never be exposed. Surface depth should comply with ASTM and CPSC specifications.
- Check for and repair damage caused by wear or vandalism, a major factor in injury causing situations.
- All protruding bolts should be covered or cut off and finished smooth. Sharp edges on pipes should be capped or removed. Check for bent, broken, or severely worn pipe, and replace.
- All equipment should be free of rust and repainted whenever necessary to deter rusting.
- We provide our customers with layout sheets and installation instructions. Please keep on file the specifications sheet that contains the listing of every part used.
- Never add components not intended for use with this product.
- Regular maintenance is necessary in this and all park and recreational equipment to insure the safety of the user.
- Note: Proper maintenance of equipment requires regular tightening of all bolts, nuts, and setscrews.
- Note: Regular checking of all parts, castings, etc. should be made. If a part is broken or worn, it should be replaced immediately.
- Check to be sure all fittings are tight and that bars and pipes do not move.
- Replace all worn S-hooks. S-hooks must be completely closed. Failure to close S-hooks can result in serious injury to the user. NEVER reuse S-hooks.
- Test for free movement of swing hanger and other moving attached parts.
- Check for worn chains and replace them.
- A soft resilient surface should be placed under all swings extending at least twice the height of the top rail both front and back.

HARDWARE

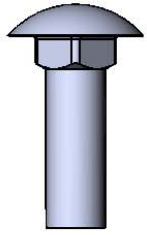

5/16" x 1"
Carriage Bolt

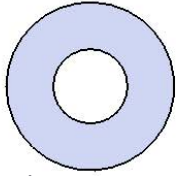

5/16" Washer

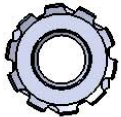

5/16" Kep Nut

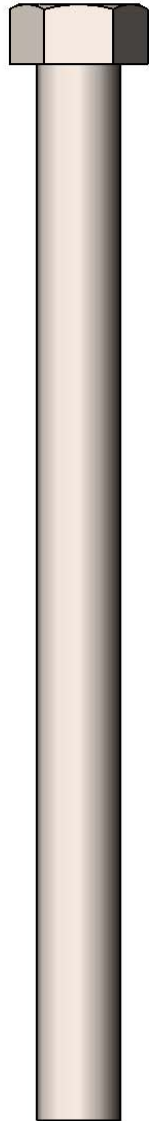

7/16" x 5"
Machine Bolt

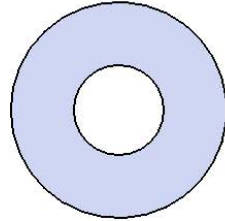

7/16" Washer

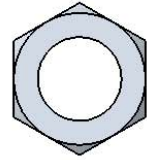

7/16" Hex Nut

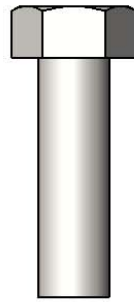

3/8" x 1-1/4"
Machine Bolt

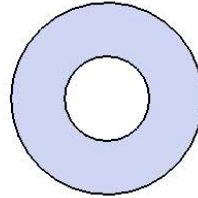

3/8" Washer

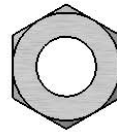

3/8" Hex Nut

TOOLS REQUIRED

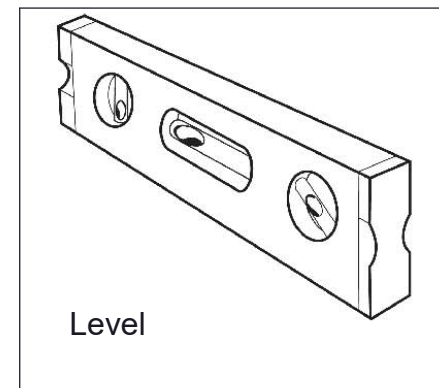
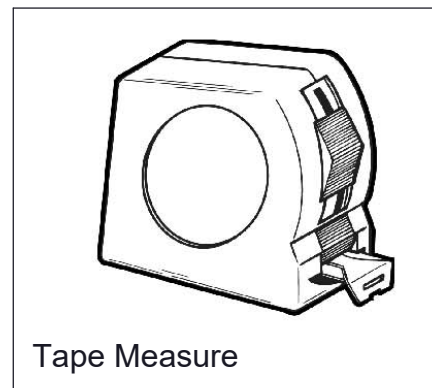
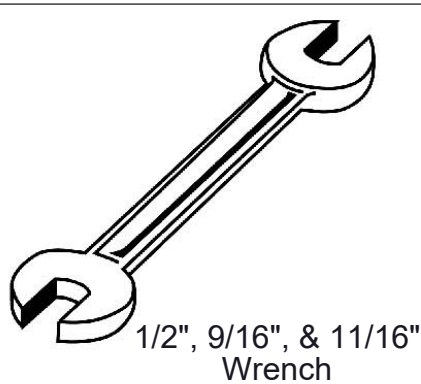

ULTRA SITE PRODUCT SPECIFICATIONS

CANOPY w/ DOUBLE BENCH 6' INGROUND CANOPY & BENCH

Seats: Seats are fabricated from 3/4" #9 steel expanded metal, CNC formed. End plates are made of 10 gauge flat steel, laser cut. Reinforced with 5/8" solid rod. Electrically MIG welded.

Canopy: 3/4" #9 steel expanded metal. Bracing is 3/16" steel plate.

Coating: Oven fused functionalized polyethylene copolymer-based thermoplastic. Fluidized bed coating application with superior mechanical performance, impact resistance and UV-stability.

Frame: 4 x 4 x 11 gauge structural steel square tubing. Seat mounting points 7 gauge x 1-1/2" die stamped steel flat bar. All electrically MIG welded.

Frame Coating: Electrostatic powder coated application oven cured.

Hardware: All stainless steel hardware fasteners.

Dimensions: 6' permanent bench w/ canopy design. Installed dimensions are 78" x 88 1/2" x 96".

COMPONENTS

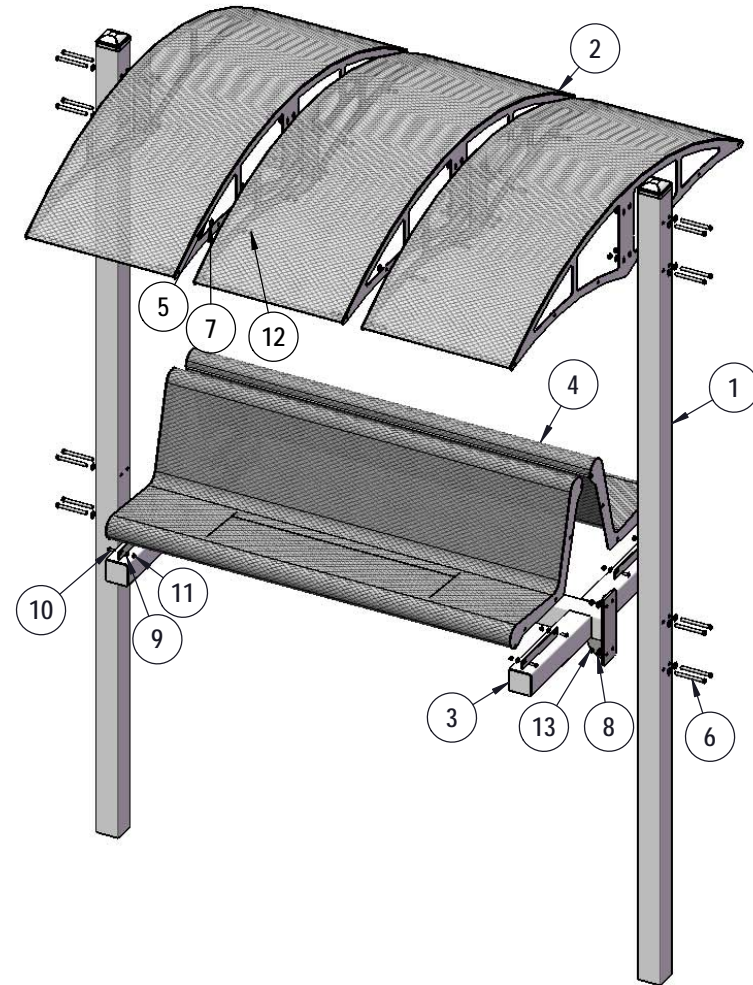
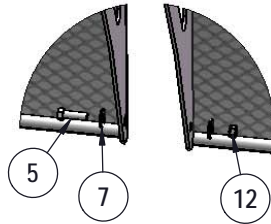

ITEM NO.	PartNo	DESCRIPTION	QTY
1	P-01-04-0314	Canopy Post with Cap	2
2	T-01-04-0320	canopy - expanded	3
3	01-04-0312	Canopy Double Bench Support	1
4	T-V72CP-S	6' expanded capri seat	2
5	33-05-0078	3/8" x 1 1/4" Machine Bolt (SS)	20
6	33-06-0080	7/16" x 5" Machine Bolt (SS)	16
7	33-02-0008	3/8" Flat Washer (SS)	40
8	33-02-0004	7/16" SS Washer	32
9	33-02-0007	5/16" SS Washer	8
10	33-06-0068	5/16" x 1" Carriage Bolt (SS)	8
11	33-03-0012	5/16" Kep Nut (SS)	8
12	33-03-0013	3/8" Kep Nut (SS)	20
13	33-01-0006	7/16" Hex Nut (SS)	16

STEP 1

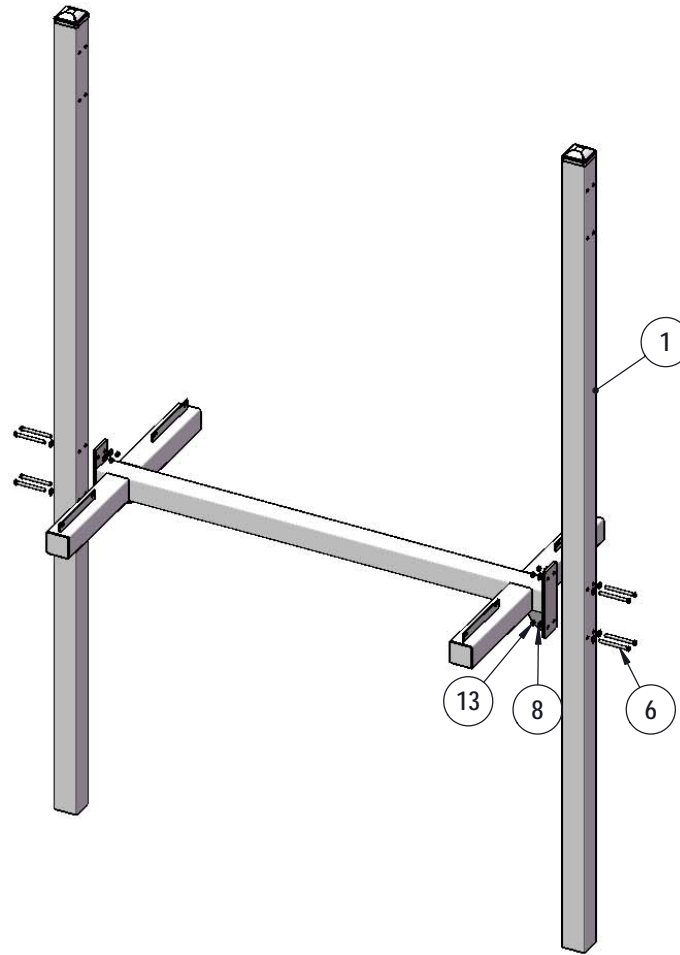

Attach the Canopy Bench Support to the Canopy Posts as shown using specified hardware.

STEP 2

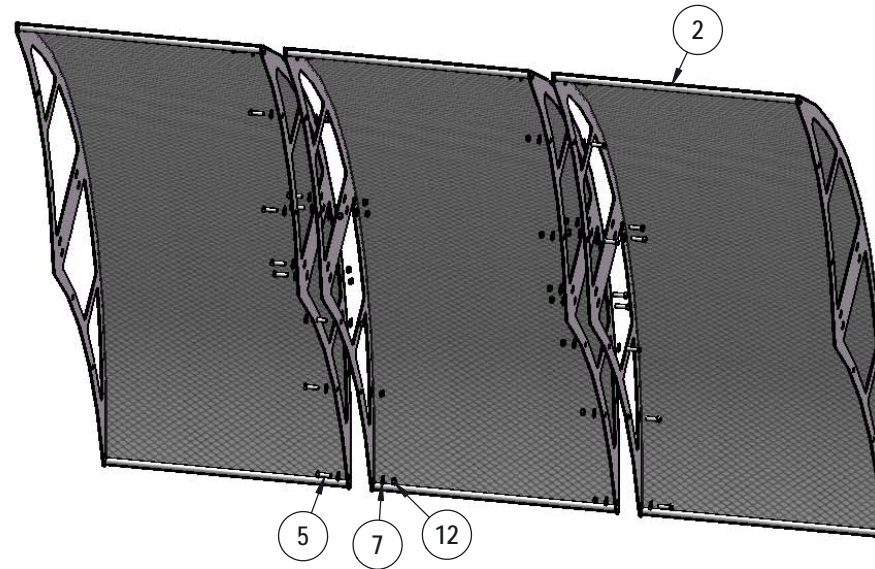

Attach the 3 Canopy Sections together as shown using specified hardware.

STEP 3

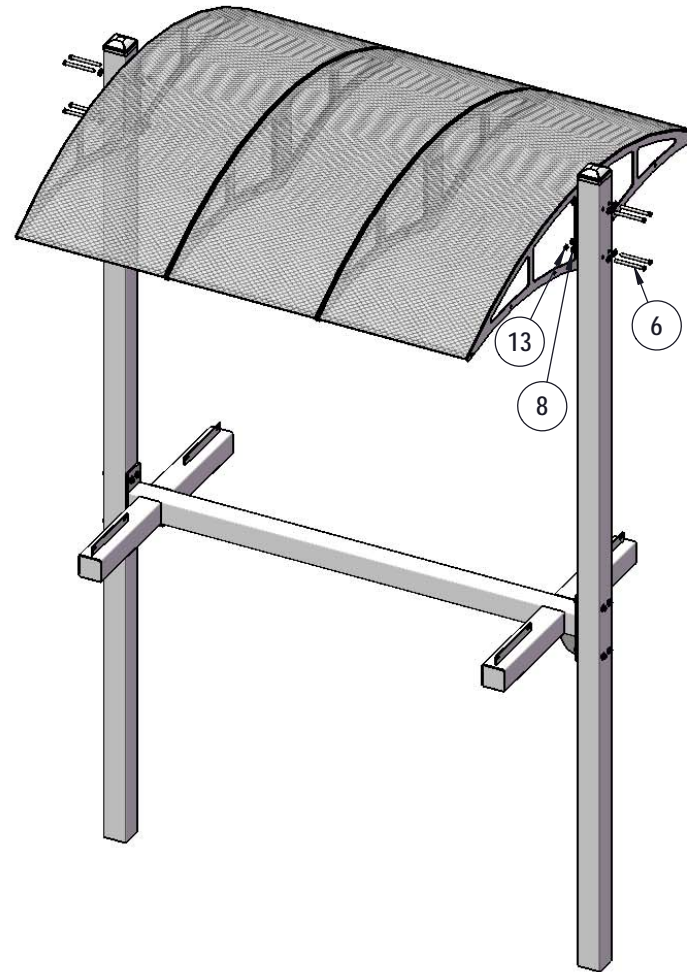

Attach the Canopy Assembly to the Canopy Posts as shown using specified hardware.

STEP 4

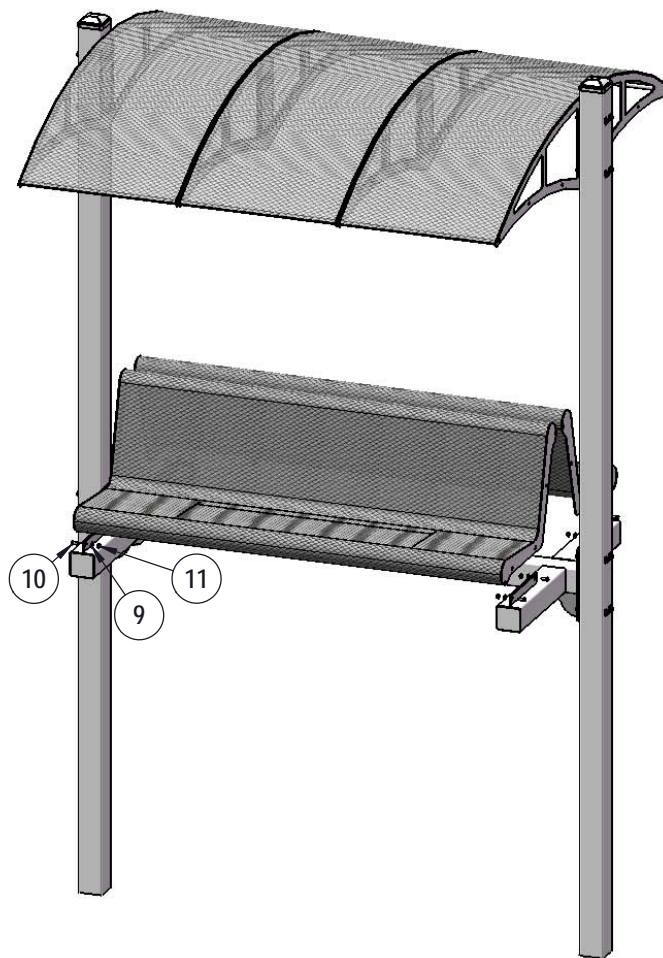

Attach the Benches to the Bench Support as shown using specified hardware.

FOOTINGS

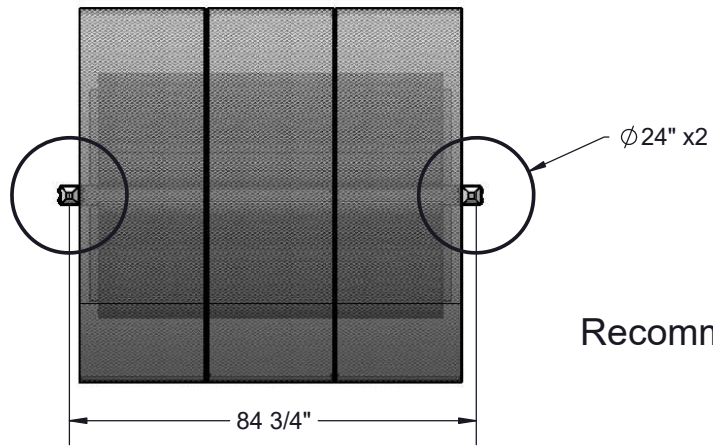

Recommended to pour footings after the assembly is complete.

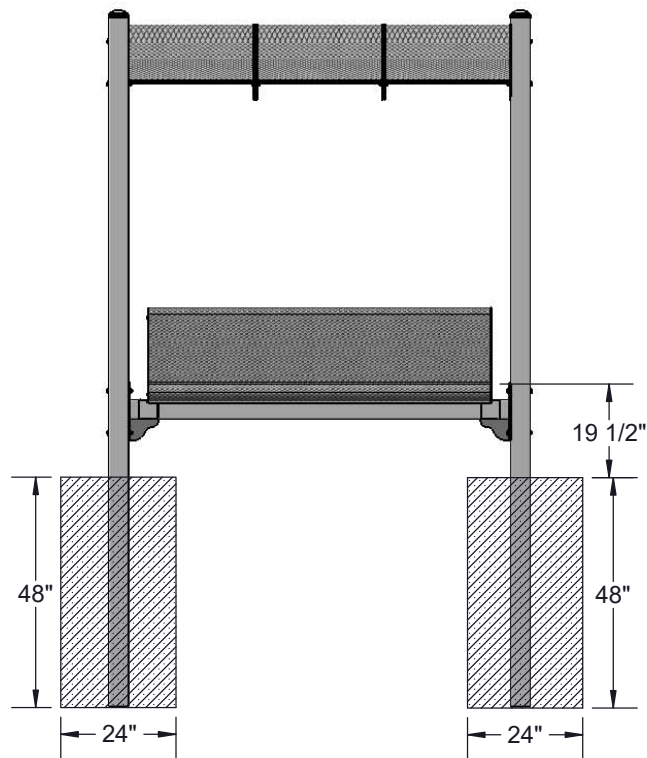

Estimated Required Concrete:
68 - 50 lb Bags of Concrete Mix

OVERALL DIMENSIONS

