

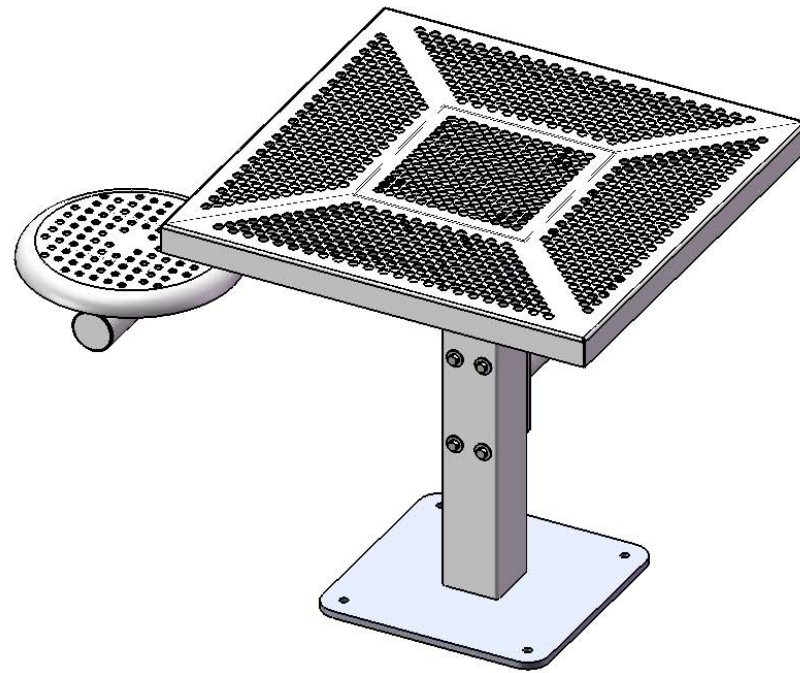

A PLAYCORE Company



Model # 501SM-P



A PLAYCORE Company

## **SAFETY WARNINGS & EQUIPMENT INSPECTION**

- Owners and installers please note these safety warnings and make use of this checklist on a regular basis.
- Follow installation instructions when erecting equipment.
- Ground surfaces around equipment should be restored as needed. Concrete footings should never be exposed. Surface depth should comply with ASTM and CPSC specifications.
- Check for and repair damage caused by wear or vandalism, a major factor in injury causing situations.
- All protruding bolts should be covered or cut off and finished smooth. Sharp edges on pipes should be capped or removed. Check for bent, broken, or severely worn pipe, and replace.
- All equipment should be free of rust and repainted whenever necessary to deter rusting.
- We provide our customers with layout sheets and installation instructions. Please keep on file the specifications sheet that contains the listing of every part used.
- Never add components not intended for use with this product.
- Regular maintenance is necessary in this and all park and recreational equipment to insure the safety of the user.
- Note: Proper maintenance of equipment requires regular tightening of all bolts, nuts, and setscrews.
- Note: Regular checking of all parts, castings, etc. should be made. If a part is broken or worn, it should be replaced immediately.
- Check to be sure all fittings are tight and that bars and pipes do not move.
- Replace all worn S-hooks. S-hooks must be completely closed. Failure to close S-hooks can result in serious injury to the user. NEVER reuse S-hooks.
- Test for free movement of swing hanger and other moving attached parts.
- Check for worn chains and replace them.
- A soft resilient surface should be placed under all swings extending at least twice the height of the top rail both front and back.

# HARDWARE

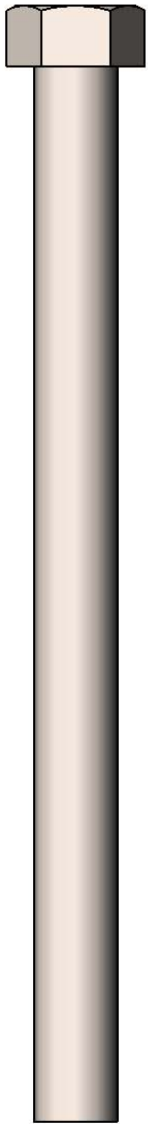

7/16" x 5"  
Machine Bolt

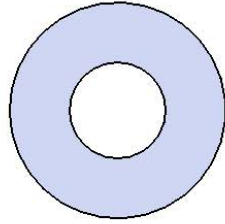

7/16" Washer

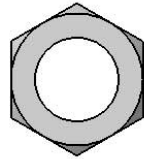

7/16" Hex Nut

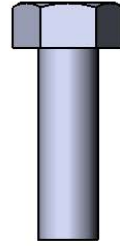

5/16" x 1"  
Machine Bolt

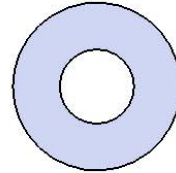

5/16" Washer

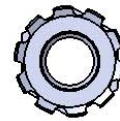

5/16" Kep Nut

## TOOLS REQUIRED

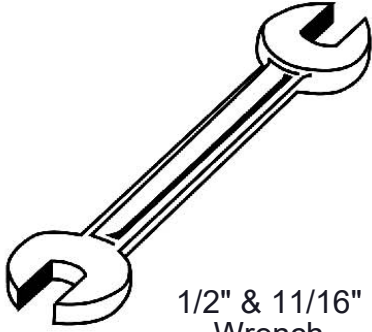

1/2" & 11/16"  
Wrench



1/2" & 11/16"  
Socket Wrench

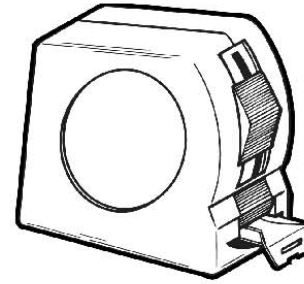

Tape Measure

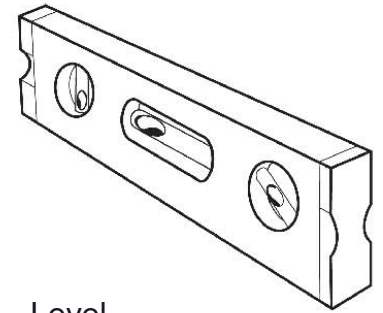

Level

# ULTRA SITE PRODUCT SPECIFICATIONS

## **501SM-P 30" SQUARE SURFACE MOUNT TABLE WITH 1 SEATS**

Top & Seats: 12 gauge sheet metal is precision punched with 5/8" diameter holes. Top is supported with 7 gauge x 1-1/2" flat bar. Electrically MIG welded. Seat is 12 ga. spun sheet steel precision punched 5/8" diameter holes.

Coating: Oven fused functionalized polyethylene copolymer-based thermoplastic. Fluidized bed coating application with superior mechanical performance, impact resistance and UV-stability.

Frame: Main support column is 4"x4"x11 gauge pre-galvanized structural steel tubing. Arms are fabricated from 2-7/8" O.D. x 12 gauge pre-galvanized structural steel tubing welded to 3/8" steel plate. Seat and top attachment points are 10 gauge precision punched. Surface Mount plate is fabricated from 16" square 1/4" thick sheet steel.

Frame Coating: Electrostatic powder coated application oven cured.

Hardware: All stainless steel hardware fasteners.

Dimensions: Top is 30" square x 30" high. Seats are 14-1/2" diameter x 18" high. Outside to outside dimensions of 1 seat table is 30" x 30" x 47-1/4".

# COMPONENTS

Attach the 30" Top to the 501/502 Post. Then attach the 501 Arm to the Post and attach the Canteen Seat to the Arm using specified hardware.

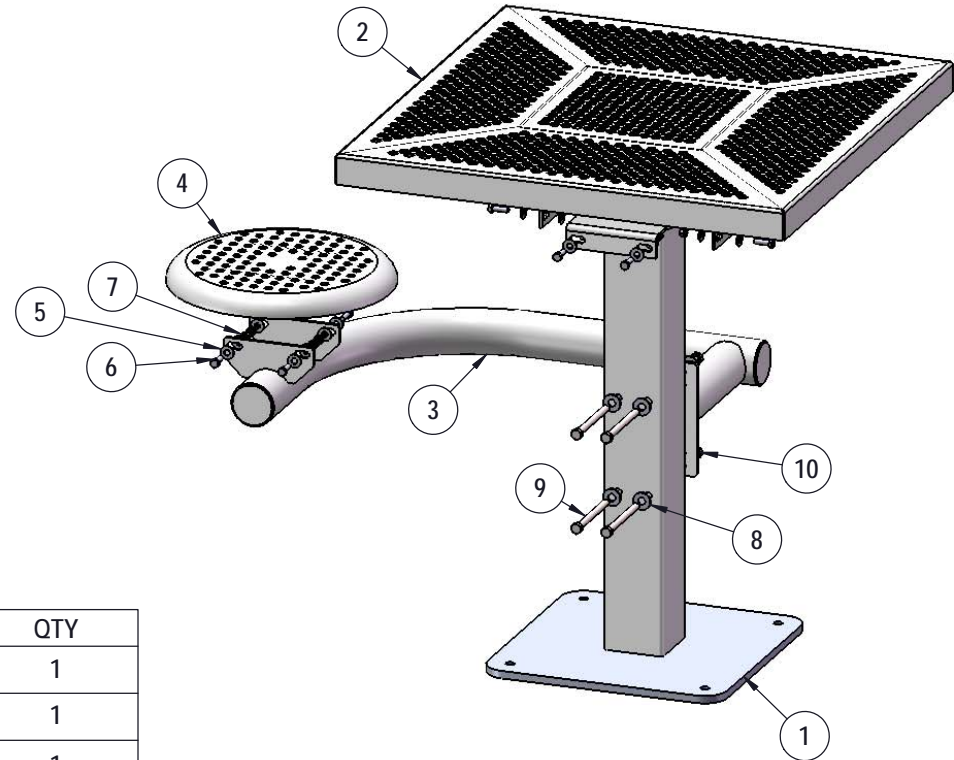

ITEM NO.	PartNo	DESCRIPTION	QTY
1	P-V501SM	501/502 single pedestal SM post	1
2	T-01-04-0284	30" sq. punched top	1
3	P-01-04-0273	501 seat arm	1
4	T-01-04-0283	canteen table spun seat	1
5	33-02-0007	5/16" SS Washer	24
6	33-05-0029	5/16" x 1" Machine Bolt (SS)	12
7	33-03-0012	5/16" Kep Nut (SS)	12
8	33-02-0013	7/16" Zinc Plated Washer	8
9	33-05-0011	7/16" x 5" Machine Bolt (Zinc)	4
10	33-01-0006	7/16" Hex Nut (Zinc)	4

# OVERALL DIMENSIONS

