

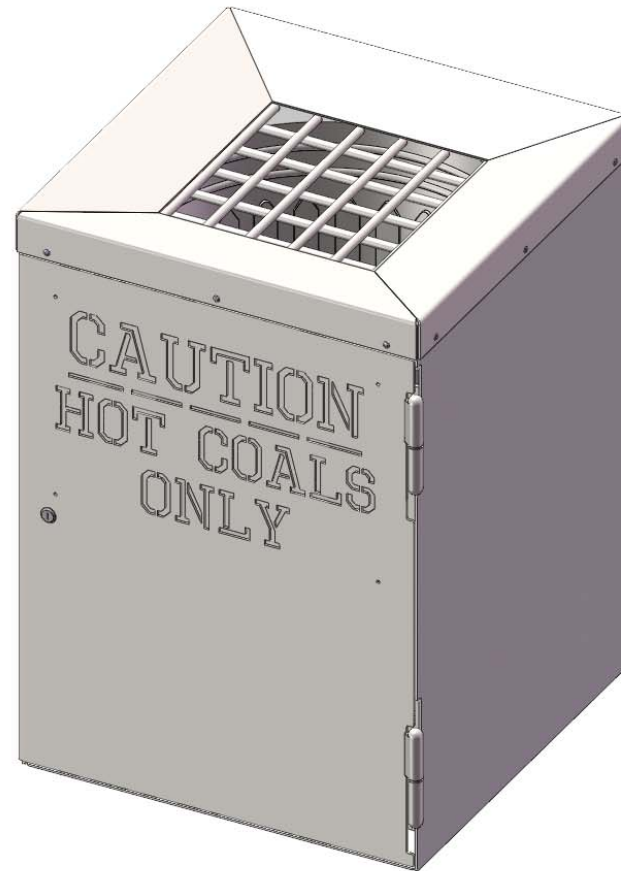

A PLAYCORE Company



Model # 675



A PLAYCORE Company

SAFETY WARNINGS & EQUIPMENT INSPECTION

- Owners and installers please note these safety warnings and make use of this checklist on a regular basis.
- Follow installation instructions when erecting equipment.
- Ground surfaces around equipment should be restored as needed. Concrete footings should never be exposed. Surface depth should comply with ASTM and CPSC specifications.
- Check for and repair damage caused by wear or vandalism, a major factor in injury causing situations.
- All protruding bolts should be covered or cut off and finished smooth. Sharp edges on pipes should be capped or removed. Check for bent, broken, or severely worn pipe, and replace.
- All equipment should be free of rust and repainted whenever necessary to deter rusting.
- We provide our customers with layout sheets and installation instructions. Please keep on file the specifications sheet that contains the listing of every part used.
- Never add components not intended for use with this product.
- Regular maintenance is necessary in this and all park and recreational equipment to insure the safety of the user.
- Note: Proper maintenance of equipment requires regular tightening of all bolts, nuts, and setscrews.
- Note: Regular checking of all parts, castings, etc. should be made. If a part is broken or worn, it should be replaced immediately.
- Check to be sure all fittings are tight and that bars and pipes do not move.
- Replace all worn S-hooks. S-hooks must be completely closed. Failure to close S-hooks can result in serious injury to the user. NEVER reuse S-hooks.
- Test for free movement of swing hanger and other moving attached parts.
- Check for worn chains and replace them.
- A soft resilient surface should be placed under all swings extending at least twice the height of the top rail both front and back.

ULTRA SITE PRODUCT SPECIFICATIONS

675 Hot Coal Bin

Hot Coal Bin Box & Door: Fabricated of laser cut formed 10 gauge steel. Electrically MIG welded.

Hot Coal Bin Top: Fabricated of laser cut formed 12 gauge steel. Electrically MIG welded.

Grate: The top grate shall be fabricated from 1/2" steel rod.

Door Backing Plate: 18 gauge steel.

Coating: Electrostatic powder coated application oven cured.

Overall Dimensions: 33-7/16" tall x 23-3/4" square. 31 gal capacity.

COMPONENTS

Hot Coal Bin will come pre-assembled.
Customer to provide their own door lock.

Top to be pop-riveted to the box. Door will attach and remove with heavy duty lift off hinges. The door allows for the inner galvanized liner to be removed and emptied.

Base plate includes 4 holes for optional mounting.

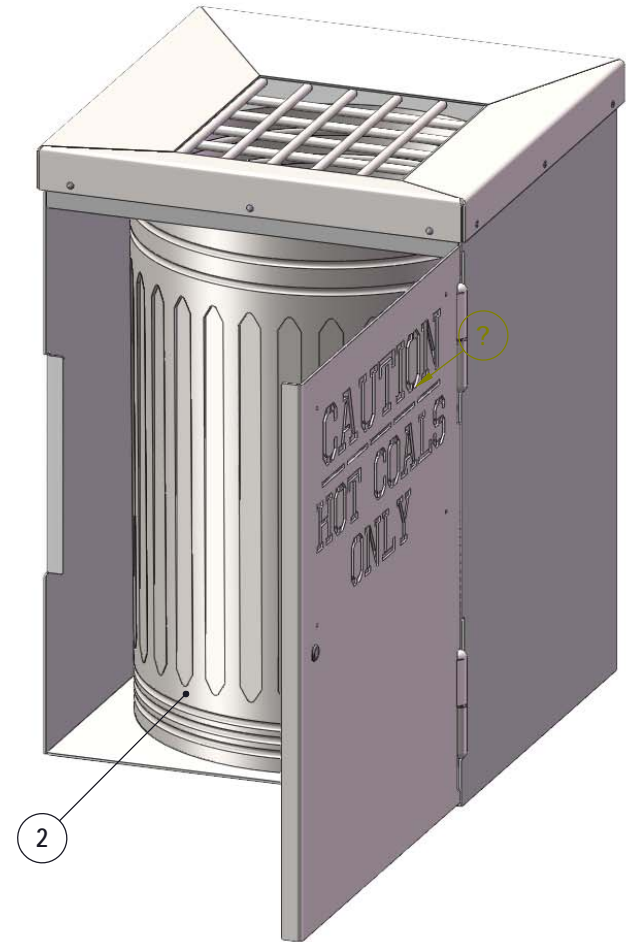
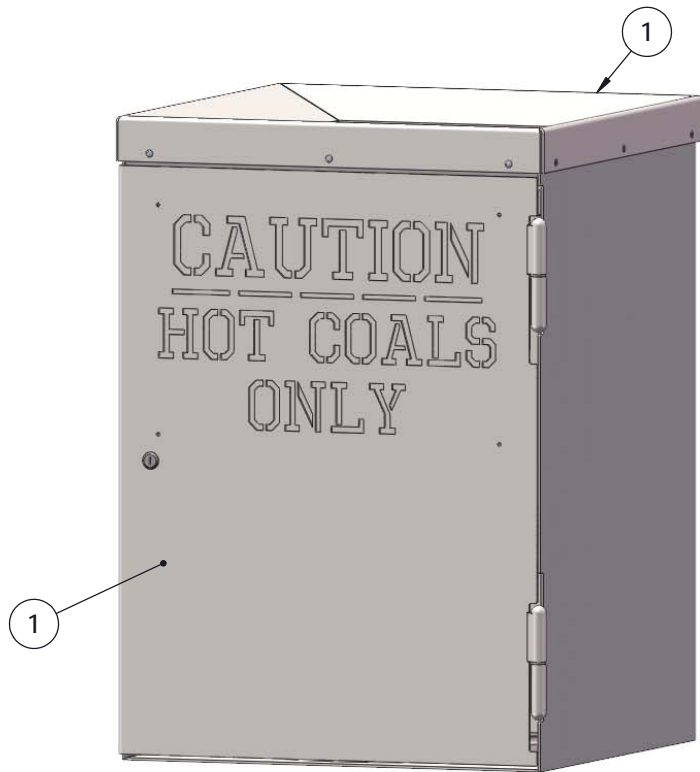

ITEM NO.	PartNo	DESCRIPTION	QTY
1	01-03-0200	Hot Coal Bin Assembly	1
2	GG31	GALVANIZED 30 GALLON CAN	1

OVERALL DIMENSIONS

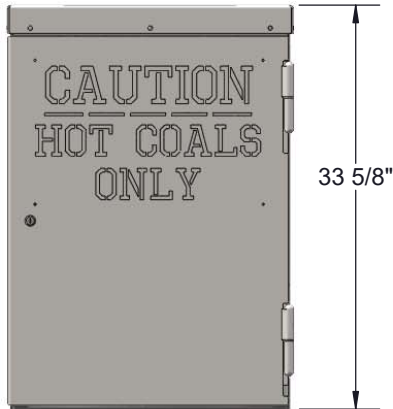
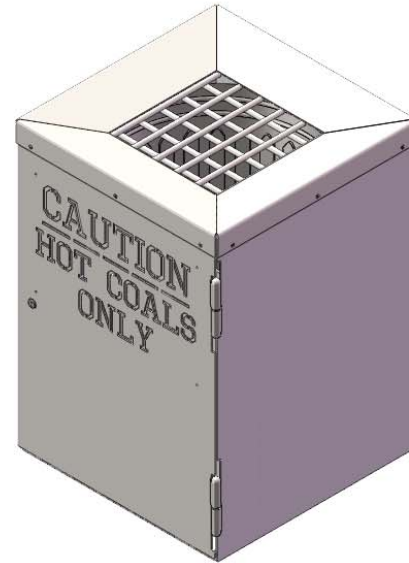
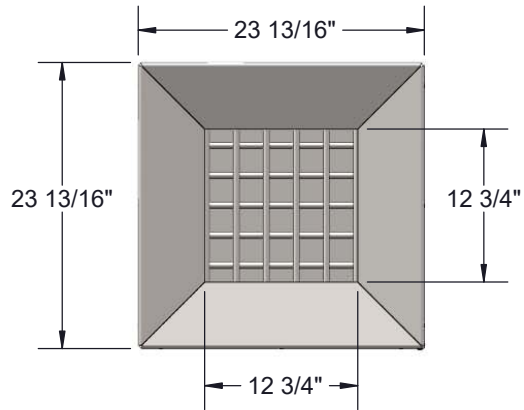

WARNING: Combustion byproducts produced when using this product include carbon monoxide, a chemical known to the State of California to cause birth defects or other reproductive harm.