



A PLAYCORE Company



Model # EX-32RB



A PLAYCORE Company

## **SAFETY WARNINGS & EQUIPMENT INSPECTION**

- Owners and installers please note these safety warnings and make use of this checklist on a regular basis.
- Follow installation instructions when erecting equipment.
- Ground surfaces around equipment should be restored as needed. Concrete footings should never be exposed. Surface depth should comply with ASTM and CPSC specifications.
- Check for and repair damage caused by wear or vandalism, a major factor in injury causing situations.
- All protruding bolts should be covered or cut off and finished smooth. Sharp edges on pipes should be capped or removed. Check for bent, broken, or severely worn pipe, and replace.
- All equipment should be free of rust and repainted whenever necessary to deter rusting.
- We provide our customers with layout sheets and installation instructions. Please keep on file the specifications sheet that contains the listing of every part used.
- Never add components not intended for use with this product.
- Regular maintenance is necessary in this and all park and recreational equipment to insure the safety of the user.
- Note: Proper maintenance of equipment requires regular tightening of all bolts, nuts, and setscrews.
- Note: Regular checking of all parts, castings, etc. should be made. If a part is broken or worn, it should be replaced immediately.
- Check to be sure all fittings are tight and that bars and pipes do not move.
- Replace all worn S-hooks. S-hooks must be completely closed. Failure to close S-hooks can result in serious injury to the user. NEVER reuse S-hooks.
- Test for free movement of swing hanger and other moving attached parts.
- Check for worn chains and replace them.
- A soft resilient surface should be placed under all swings extending at least twice the height of the top rail both front and back.

# ULTRA SITE PRODUCT SPECIFICATIONS

## EX-32RB 32 GALLON TRASH RECEPTACLE THERMO, RAIN BONNET LID & LINER

Receptacle Coating: Oven fused functionalized polyethylene copolymer-based thermoplastic. Fluidized bed coating application with superior mechanical performance, impact resistance and UV-stability.

Material: 3/4" #9 steel expanded metal. 11 gauge x 1-1/2" flat strip border the top and bottom of the expanded metal, and the vertical seam. Bottom plate fabricated from 11 gauge sheet steel laser cut for a precision fit. Top plate shall be fabricated from 18 gauge steel flat, spun to form. Vertical posts are 1/2" diameter steel rods. Bonnet top shall be fabricated from 20 gauge steel flat, spun to form. All electrically MIC welded.

Coating: Oven fused functionalized polyethylene copolymer-based thermoplastic. Fluidized bed coating application with superior mechanical performance, impact resistance and UV-stability.

Receptacle Dimensions: 23-1/4" diameter x 29-3/4" high x 32 gallon capacity.

Receptacle Top Dimensions: Center opening shall be 8" inside diameter. The overall dimensions shall be 24" diameter x 11" high.

32 Gallon Liner: Made from heavy duty plastic.

Hardware: Attachment hardware and mounting kit not included (7/16" diameter holes provided in receptacle for mounting).

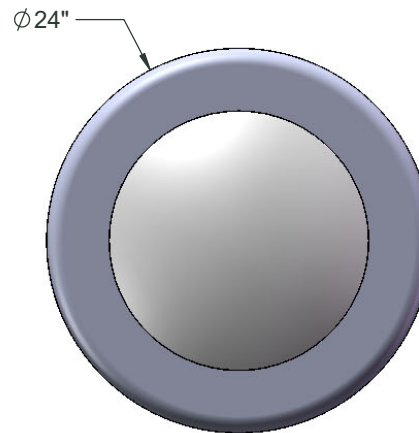
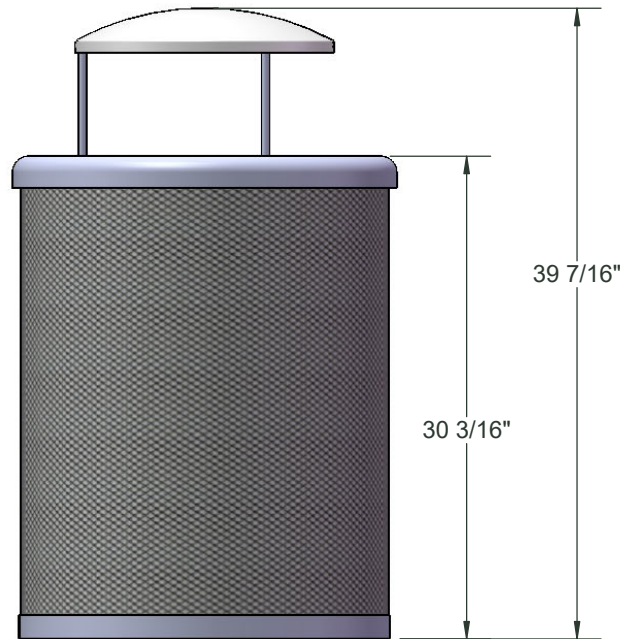

# IN-GROUND MOUNTING OPTION

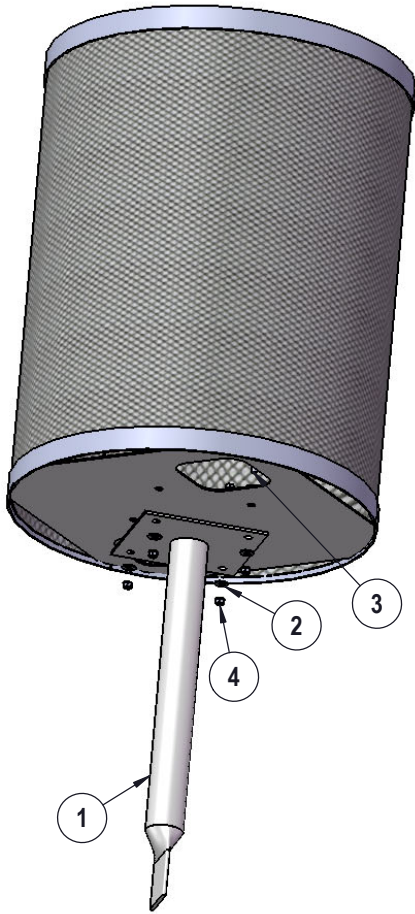

IG KIT

## INGROUND MOUNT FOR TRASH RECEPTACLE

Frame: 2- 3/8" O.D. x 12 gauge pre-galvanized structural steel tubing.  
 Receptacle mounting plates are 7 gauge x 8" x 8" steel plate with 4 holes.

Frame Coating: Electrostatic powder coated application oven cured.

Hardware: All stainless steel hardware fasteners. (Included).

Dimensions: Overall dimension is 24 1/4" x 8" x 8".

### Mounting kits sold separately

Attach the IG KIT to the EX-32 as shown using specified hardware.

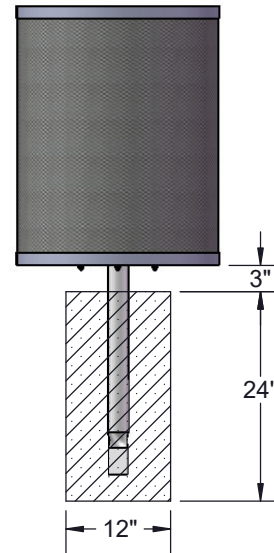

Estimated Required Concrete:  
 5 - 50lb Bags of Concrete Mix

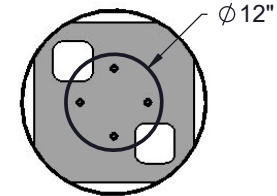

ITEM NO.	PartNo	DESCRIPTION	QTY
1	P-01-05-0052	receptacle inground mount	1
2	33-02-0007	5/16" SS Washer	8
3	33-05-0029	5/16" x 1" Machine Bolt (SS)	4
4	33-03-0012	5/16" Kep Nut (SS)	4

# SURFACE MOUNT MOUNTING OPTION

## SURFACE MOUNT FOR TRASH RECEPTACLE

Frame: 2- 3/8" O.D. x 12 gauge pre-galvanized structural steel tubing.  
Receptacle mounting plates are 7 gauge x 8" x 8" steel plate with 4 holes .  
Surface mounting plates are 1/4" x 6" x 6" steel plate with 4 holes.

Frame Coating: Electrostatic powder coated application oven cured.

Hardware: All stainless steel hardware fasteners. (Included).

Dimensions: Overall dimension is 3-3/4" x 8" x 8".

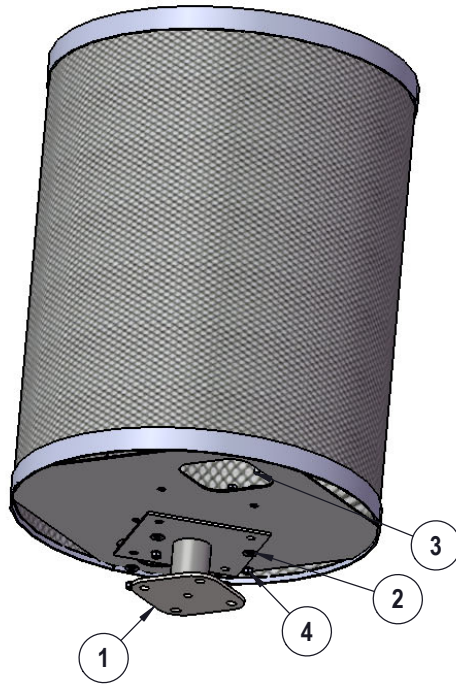

SM KIT

### Mounting kits sold separately

Attach the SM KIT to the EX-32 as shown using specified hardware.

Recommended Surface Mount Hardware:  
3/8" x 3-1/2" Concrete Expansion Anchor Bolts  
(Not Included)

ITEM NO.	PartNo	DESCRIPTION	QTY
1	P-01-05-0053	receptacle surface mount	1
2	33-02-0007	5/16" SS Washer	8
3	33-05-0029	5/16" x 1" Machine Bolt (SS)	4
4	33-03-0012	5/16" Kep Nut (SS)	4

# TOOLS AND HARDWARE REQUIRED FOR MOUNTING OPTIONS

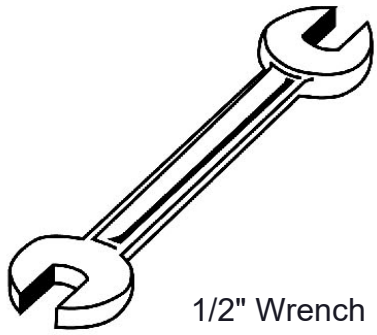

1/2" Wrench

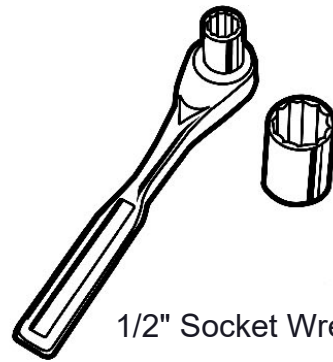

1/2" Socket Wrench

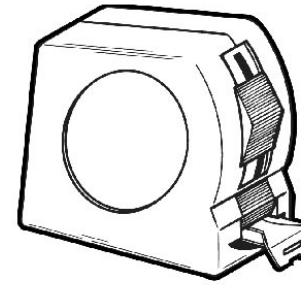

Tape Measure

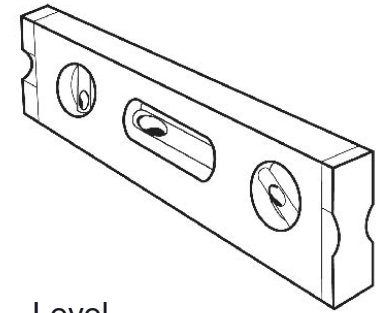

Level

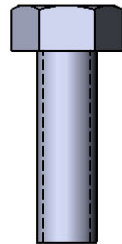

5/16" x 1"  
Machine Bolt

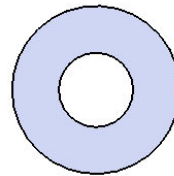

5/16" Washer

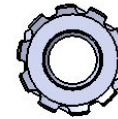

5/16" Kep Nut