

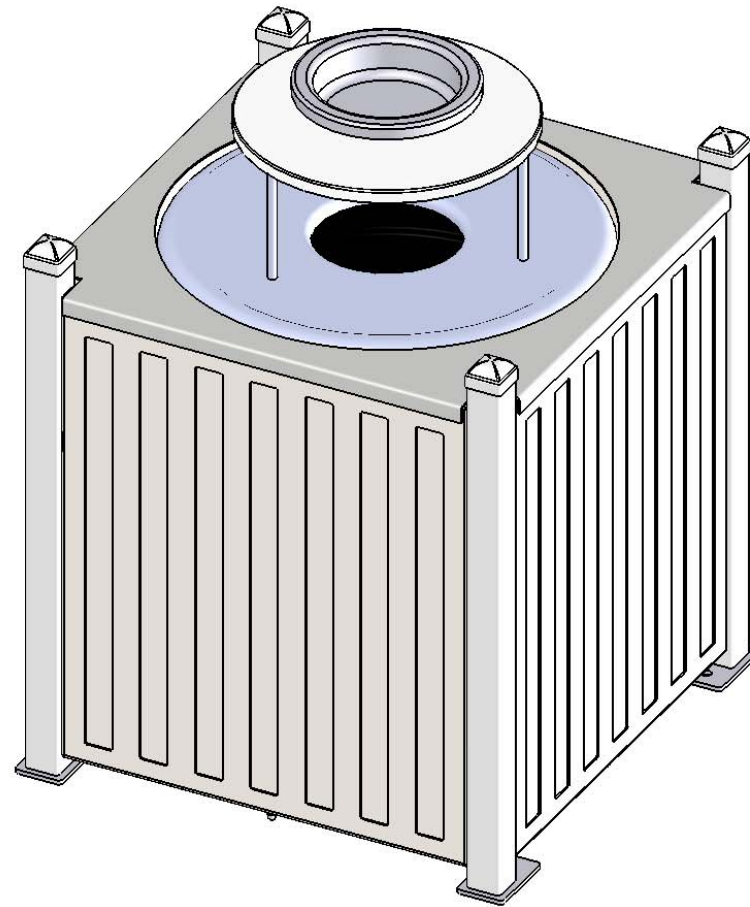

A PLAYCORE Company



Model # SV-S32AU



A PLAYCORE Company

SAFETY WARNINGS & EQUIPMENT INSPECTION

- Owners and installers please note these safety warnings and make use of this checklist on a regular basis.
- Follow installation instructions when erecting equipment.
- Ground surfaces around equipment should be restored as needed. Concrete footings should never be exposed. Surface depth should comply with ASTM and CPSC specifications.
- Check for and repair damage caused by wear or vandalism, a major factor in injury causing situations.
- All protruding bolts should be covered or cut off and finished smooth. Sharp edges on pipes should be capped or removed. Check for bent, broken, or severely worn pipe, and replace.
- All equipment should be free of rust and repainted whenever necessary to deter rusting.
- We provide our customers with layout sheets and installation instructions. Please keep on file the specifications sheet that contains the listing of every part used.
- Never add components not intended for use with this product.
- Regular maintenance is necessary in this and all park and recreational equipment to insure the safety of the user.
- Note: Proper maintenance of equipment requires regular tightening of all bolts, nuts, and setscrews.
- Note: Regular checking of all parts, castings, etc. should be made. If a part is broken or worn, it should be replaced immediately.
- Check to be sure all fittings are tight and that bars and pipes do not move.
- Replace all worn S-hooks. S-hooks must be completely closed. Failure to close S-hooks can result in serious injury to the user. NEVER reuse S-hooks.
- Test for free movement of swing hanger and other moving attached parts.
- Check for worn chains and replace them.
- A soft resilient surface should be placed under all swings extending at least twice the height of the top rail both front and back.

HARDWARE

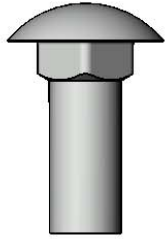

3/8" x 1"
Carriage Bolt

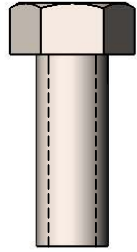

3/8" x 1"
Machine Bolt

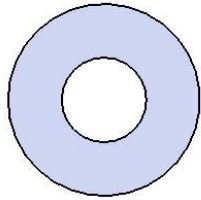

3/8" Washer

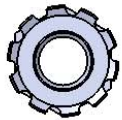

3/8" Kep Nut

TOOLS REQUIRED

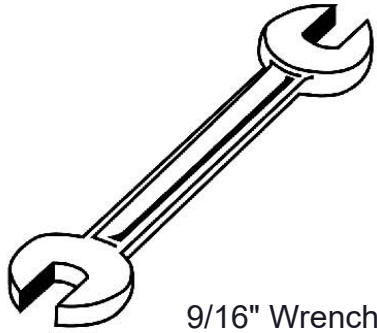

9/16" Wrench



9/16" Socket Wrench

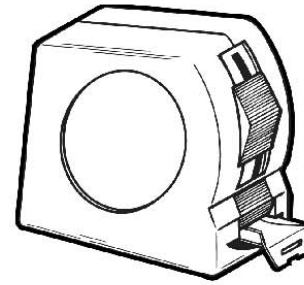

Tape Measure

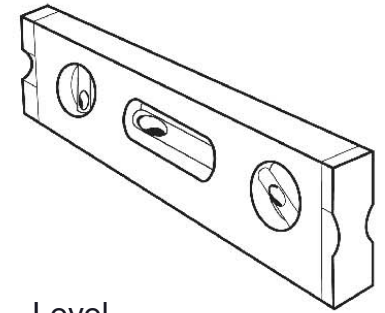

Level

ULTRA SITE PRODUCT SPECIFICATIONS

SV-S32 32 GALLON TRASH RECEPTACLE

Material: Top & bottom are fabricated from 11 gauge steel flat plate. Sides are made from 12ga formed laser cut steel plate. Frame is made of 2" square tubing. Surface mount plates are laser cut from 1/4" steel plate. Backing plate shall be formed from 18ga steel sheet.

Coating: Oven fused functionalized polyethylene copolymer-based thermoplastic. Fluidized bed coating application with superior mechanical performance, impact resistance and UV-stability. Optional: Steel is sandblasted to near white condition. Coated with zinc rich epoxy primer and top coated with electrostatic powder coat, oven cured.

Receptacle Dimensions: 28" square x 32" high x 32 gallon capacity.

Hardware: Mounting hardware not included.

AU-32-08 32 GALLON ASH URN TOP

Material: Top plate shall be fabricated from 18 gauge steel flat, spun to form. Vertical posts are 1/2" diameter steel rods. Bonnet top shall be fabricated from 20 gauge steel flat, spun to form. Ash urn shall be fabricated from 20 gauge steel flat, spun to form. All electrically MIG welded.

Coating: Oven fused functionalized polyethylene copolymer-based thermoplastic. Fluidized bed coating application with superior mechanical performance, impact resistance and UV-stability. Optional: Steel is sandblasted to near white condition. Coated with zinc rich epoxy primer and top coated with electrostatic powder coat, oven cured.

Receptacle Dimensions: Center opening shall be an 8" inside diameter. The overall dimensions shall be 24" diameter x 11-1/4" high.

PL-32: Made of Heavy Duty Plastic

Overall Dimensions Including Top: 28" Square x 40-1/2" High x 32 gallon capacity.

COMPONENTS

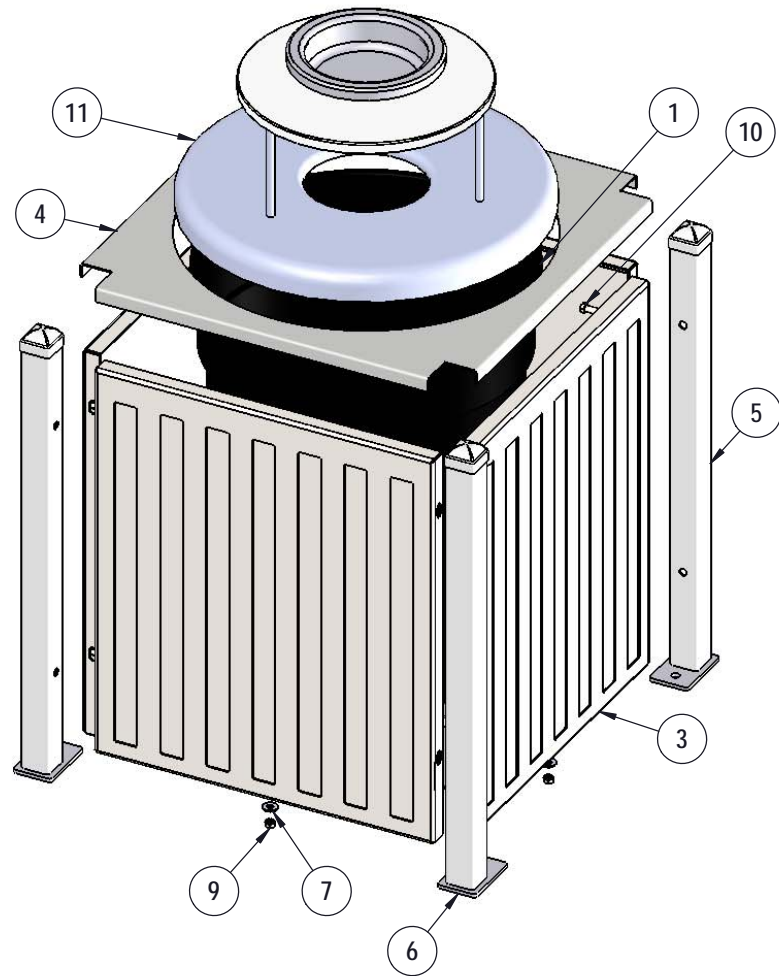

ITEM NO.	PartNo	DESCRIPTION	QTY
1	PL-32	32 Gal. Liner	1
2	01-05-0057	Sav Receptacle Bottom Plate	1
3	01-05-0062	Sav Side Panel Slat	4
4	01-05-0056	Sv Flat Top Holder	1
5	T-SV32-R	Sav Receptacle 32 Frame RH	2
6	T-SV32-L	Sav Receptacle 32 Frame LH	2
7	33-02-0008	3/8" Flat Washer (SS)	20
8	33-06-0042	3/8" x 1" Carriage Bolt (SS)	4
9	33-03-0013	3/8" Kep Nut (SS)	4
10	33-06-0056	3/8" x 1" Machine Bolt (SS)	16
11	(T/P) AUR-32-08	32 Gallon Rolled Ash Urn with a 8" opening	1
12	01-05-0226	savannah receptacle inner backing plate	4

Optional Surface Mount Hardware:
 3/8" x 3-1/2" Concrete Expansion Anchor Bolts
 (Not Included)

STEP 1

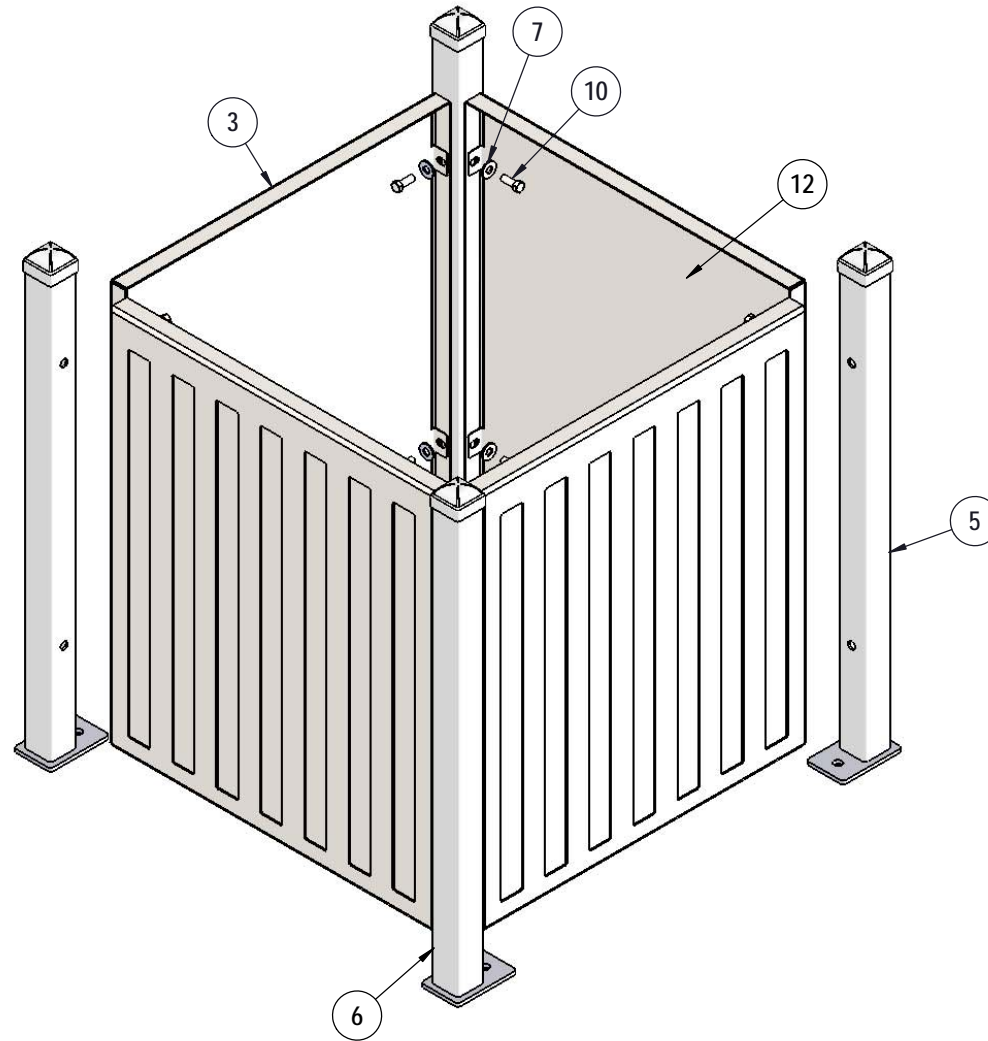

Attach the Slat Panels and Backing Plates to the Savannah Frames as shown using specified hardware.

STEP 2

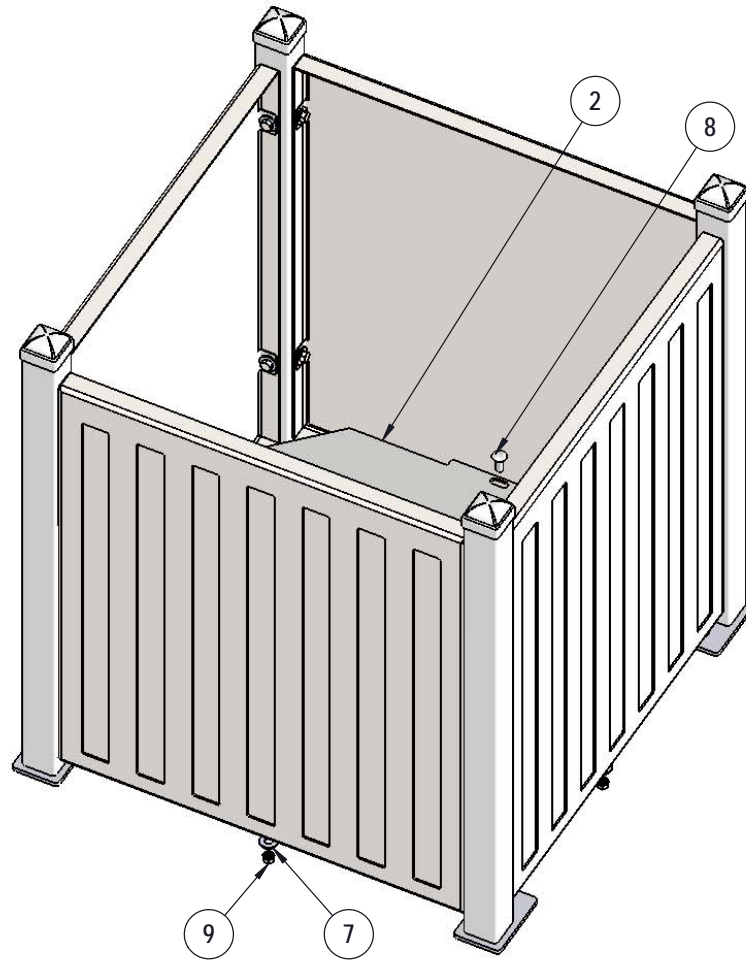

Insert the Savannah Bottom Plate into the assembly as shown and fasten using specified hardware.

STEP 3

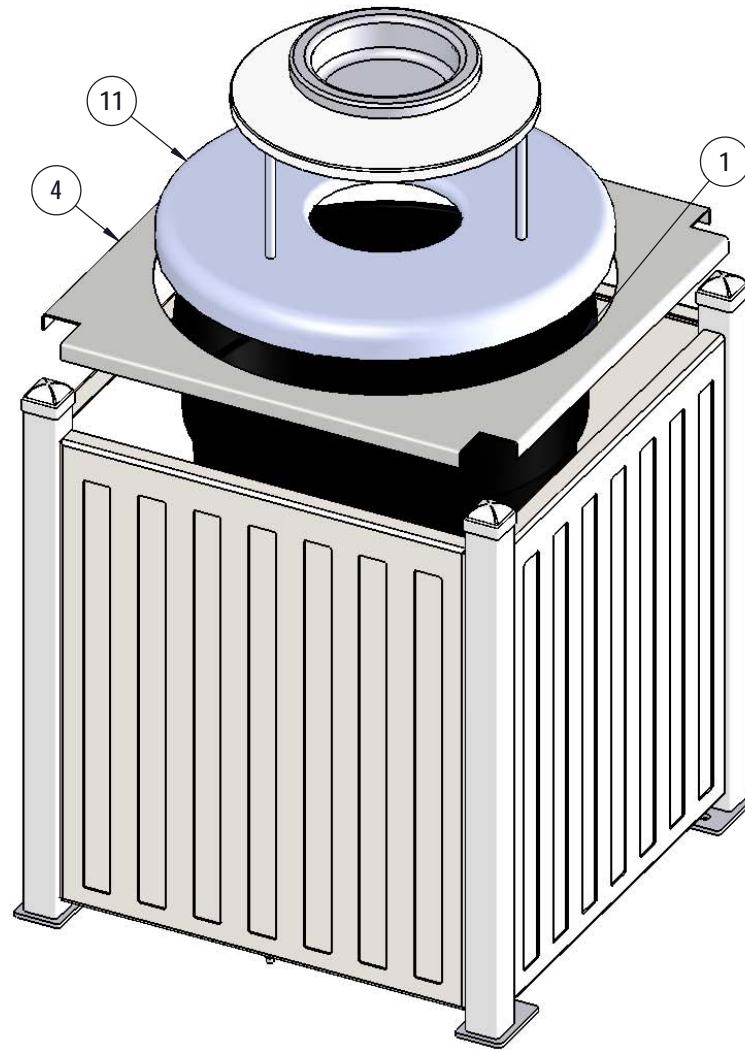

Place 32 Gallon Liner into assembly, then place Savannah Top Holder and Ash Urn on top of the assembly as shown.

OVERALL DIMENSIONS

